

# DTI Technical Brief

---

## Solid State High Voltage DC Power Distribution & Control

Dr. Marcel P.J.Gaudreau P.E., Dr. Jeffrey A. Casey, Timothy J. Hawkey, Michael A. Kempkes,  
J. Michael Mulvaney, Dr. Peter Ver Planck

---

### *Abstract*

Future high voltage, high power systems in the early stages of planning include U.S. large accelerator programs such as the Next Linear Collider (NLC), Accelerator Production of Tritium (APT), Spallation Neutron Source (SNS), and international systems at DESY, CERN and KEK. There are also many nuclear fusion and multi-megawatt systems proposed for construction or upgrade. Each of these programs faces the challenge of distributing and controlling the high power required by tens to hundreds of RF amplifier tubes (e.g., klystrons) cost effectively. Designing, configuring, and procuring a high voltage, high average power system, and achieving a successful balance among the conflicting goals of cost, performance, and reliability is a significant challenge.

In this paper, we present a new approach for distributing and modulating power based upon recent technological developments in high voltage, high power, solid state switching. It is now feasible to implement a DC power distribution and control system that is more efficient, more reliable, and cheaper to procure and operate than conventional 3-phase 50/60 Hz distribution systems.

The key to this approach is DTI's development of fast, high voltage, opening and closing solid state switches that operate at 100+ kV and current levels up to 2000 A. These switches enable, for the first time at high voltage, a nearly lossless "DC Transformer". With this DC transformer (i.e., down converter or buck regulator), it is now possible to distribute unregulated high voltage DC power in a large facility, and regulate and control it at the klystron. For power distribution, control, and fault protection a system based upon this approach is significantly smaller, less expensive, and more reliable than conventional methods

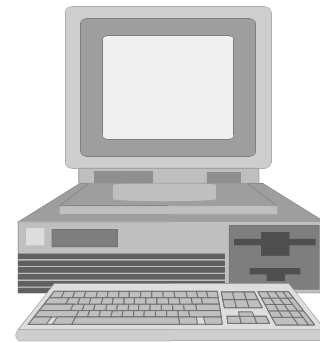

### *Introduction*

#### **A Well Known Solid State Triumph**

An excellent analogy for the concept we are proposing in this paper is the success of the personal computer (PC). Several characteristics of the PC are relevant to this discussion.

First, the PC uses a solid-state, switching power supply, transforming AC input power into DC power for use by the computer's internal devices. Most people think of this as low voltage, but, like the systems we are discussing, many PCs contain a high voltage vacuum (monitor) tube, which must also be powered.

Second, the PC represents the modern apex of the benefits of solid state technology. Its cost/performance curve is unparalleled in any field; its modularity makes it repairable at low cost; and it is adaptable to virtually any field of endeavor. In the field of high voltage power distribution, solid state switches can create the same benefits for exactly the same reasons.

#### **The Opportunity**

Recent advances in high power solid state electronics encourage a re-examination of how power is distributed in high voltage, high power systems. Primarily, these advances have been enabled by (1) the commercial availability of high power solid state devices, such as

Insulated Gate Bipolar Transistors (IGBTs), capable of handling hundreds of kilowatts each; and (2) the development of effective methods for combining these devices into very high power circuits. These technological advancements permit two fundamental changes to occur: DC Power Distribution and High Frequency Solid State Power Control.

The early 20<sup>th</sup> century saw the triumph of Westinghouse's AC power distribution scheme over Edison's DC distribution approach because efficient AC power transformers were available and DC transformers were not.

Today, solid state power technology enables the development of efficient DC voltage transformers, creating the potential for the replacement of traditional AC distribution technology.

Conventional power control for transmitters is provided by vacuum tubes for voltage and current regulation and fault isolation. Solid state switches can be configured to provide superior power control more cheaply, with greater efficiency, reliability, and with a smaller footprint than vacuum tube technology.

## ***The Present***

### **Proven Over 40 Years, But...**

Power distribution systems for radars, accelerators, and other high power RF systems have remained essentially unchanged since WWII. AC power is transported and transformed over a complex network of transformers, rectifiers, converters and vacuum tube switches from its source, to a RF vacuum tube. AC distribution is expensive, complex to manufacture and maintain, and inefficient. Typically, only 10% to 20% of the grid power provided to these systems is converted to RF power. The rest is converted to heat, which must then be removed via another complex set of plant structures.

### **Conventional Power Distribution and Control**

Figures 1-3 on the next pages show the hardware required for some of the key steps in the conventional method of distributing and controlling power from the utility grid to an RF klystron.

Figures 3A and 3B represent a conventional distribution scheme to deliver approximately 100 MW of RF klystron power. The route power takes to one klystron is shown in detail. Along the bottom of Figure 3A is a scorecard which totals the number of components required at each stage of the process. For

example, 100 SCR controllers and 100 input crowbars are needed for the overall system represented by the drawing. The photographs that follow illustrate the key steps in the AC power distribution scheme.

### **1. High Voltage Distribution**

Three-phase high voltage power is taken from the utility power grid in an outdoor switchyard, as shown in Figure 1. High Voltage AC power, typically at 230



*Figure 1: Typical 100 MW Power Distribution Circuit Breaker Yard System*

kV or higher, is routed through oil or SF<sub>6</sub> (silicon hexafluoride) switchgear prior to going to the step-down transformers as shown in Figure 2.

### **2. Step Down Transformer**

The first step in the power conversion process, shown in Figure 2 is a step-down transformer, used to reach a convenient voltage for local distribution. Note the scale of the transformer and the workman standing beside it. Power distributed from the source in Figure



*Figure 2: 115kV to 13.8kV AC Transformer*

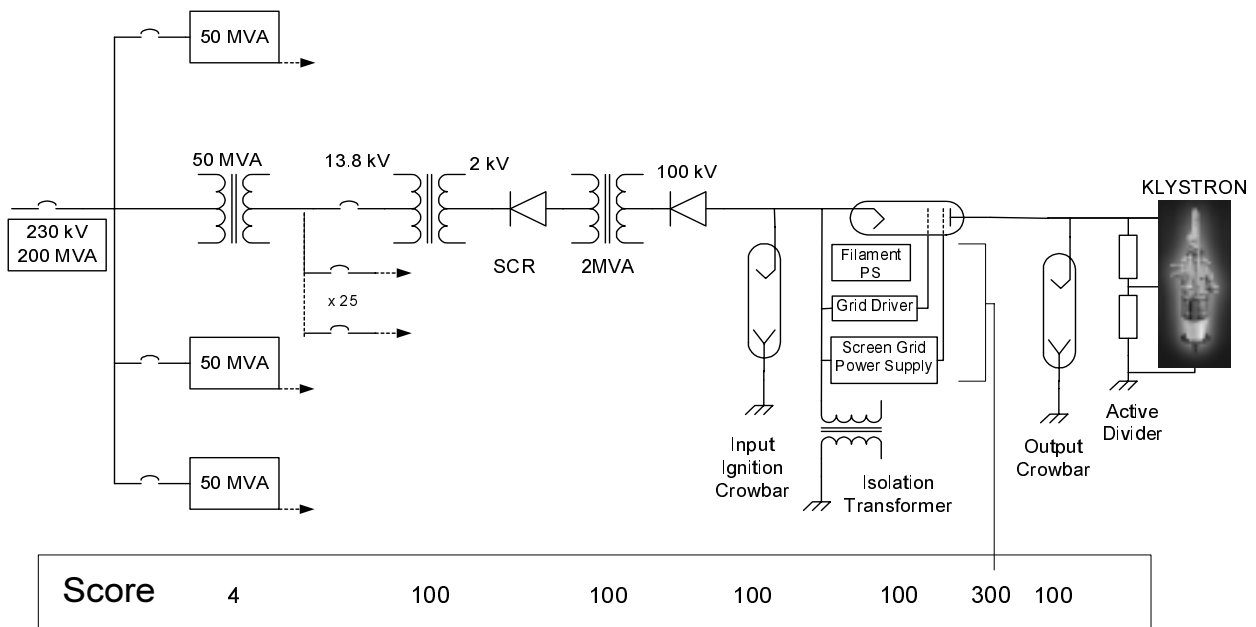

Figure 3A



Figure 3B

1 is transformed from 115 or 230kVAC to (typically) 13.8kV AC by the step-down transformer, which produces up to 125MVA with forced oil and air-cooling.

### 3. Switch House

Power at 13.8kV is typically routed via underground cables to a switch house where rows of large circuit breakers control the many 13.8KV circuits for distribution. The photograph in Figure 3 shows

typical circuit breakers at the right hand side of the photograph.

### 4. Medium Voltage Step-down Transformer

Another set of large transformers converts the 13.8kV to 2kV, 1000A unregulated AC power. each transformer measures approximately 10' x 10' x 10'.

### 5. SCR Control

The next step is SCR voltage control at 2 kV using more fault isolation circuit breakers. The photograph



*Figure 4: 2 MW Transformer*

above shows the enclosure housing the SCR controls for four 2 MW power supplies.

### **6. Step Up Transformer/Rectifier**

The transformer in the center of Figure 3 and in Figure 4, transforms and rectifies the 2kVAC power to 100kVDC power. Its output is approximately 20A, providing 2 MW of DC power for the klystrons in the LEDA experiment at LANL.

### **7. Switch Tube / Regulator / Crowbar**

Typically, the final components in the power chain ahead of the klystrons are vacuum tubes (such as a thyatron crowbar) for arc protection, and a series switch tube for current regulation and/or pulse modulation. The chief function of these tubes is to protect the klystrons from the very large energy levels stored in the power supply in the event of a klystron fault. In some configurations, the switch tube itself may also require crowbar protection.

The size and cost of the AC power distribution system is primarily driven by the equipment required to transform this high power a total of four times between the grid and the klystron (230 kVAC to 13.8 kVAC to 2 kVAC to 100 kVDC). These transformers, as shown in Figures 2, 3, and 4 are very large and expensive pieces of custom equipment.

### ***DC Power Distribution & Control***

Until recently there were no alternatives to the traditional power distribution and control configuration

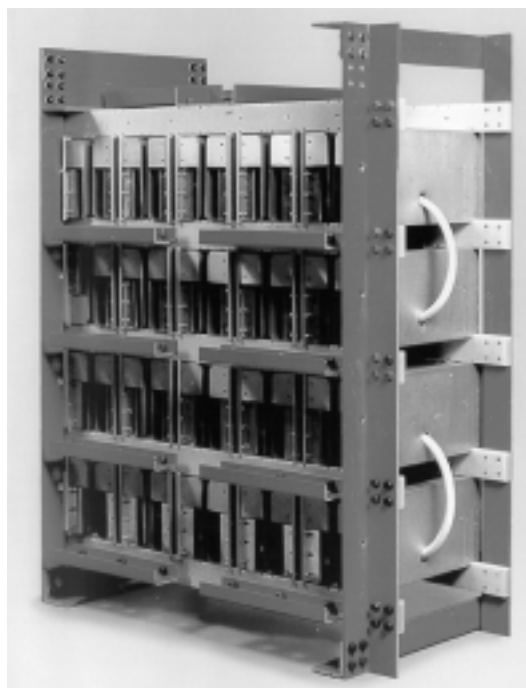

*Figure 5: PowerMod™ 125kV, 400A Solid State Switch (Approx: 50" x 41" x 20")*



*Figure 6: PowerMod™ HVPM 100-150 Solid State Modulator*

described above, and the cost and complexity of this approach, though significant, were unavoidable.

DTI's recent developments offer the functionality of the tube-based systems at significantly higher efficiency and lower cost. The key technology for this new approach is the availability of a fast, high voltage,

PowerMod™ 100-150 Specifications	
Control Power	120 VAC @ 10A
High Voltage Input	1-100 kV Peak
Average Pulse Current	150 A
Rise Time*	<1 $\mu$ s
Fall Time*	<1 $\mu$ s
Nominal Pulse Width	1 $\mu$ s - 100 $\mu$ s
Nominal Pulse Frequency	0 - 5, 000 Hz

\*into resistive load

Table 1

solid state, opening and closing switch.

Figure 5 shows a DTI PowerMod™ high voltage, solid state switch which operates at 125 kV, 400A, and up to 50 kHz in burst mode. This patented switch technology is the core of DTI's commercial modulators, such as the HVPM 100-150 shown in Figure 6. This unit's specifications are shown in Table 1. Figure 7 shows a typical pulse from this modulator. DTI's ability to build a solid state, high voltage switch that both opens and closes rapidly is the key to the next generation of power distribution and control systems.

Using DTI's high voltage solid state switching technology, the power distribution picture is dramatically simplified. This design promises reduced complexity and the potential for significantly lower acquisition costs and long-term operating costs.

Figure 10 illustrates one possible configuration of this new approach to delivering power to a klystron. It illustrates the concept of transformed three-phase DC power supplied to devices called "switching buck regulators". The following components comprise this architecture:

### 1. High Voltage Distribution

Three-phase high voltage power is taken from the power grid in an outdoor switchyard, as shown previously in Figure 1. High voltage AC power, typically at 230 kV or higher, is routed through large SF<sub>6</sub> circuit breakers prior to going to the step-down transformer as shown in Figure 2. This step is identical to the conventional approach.

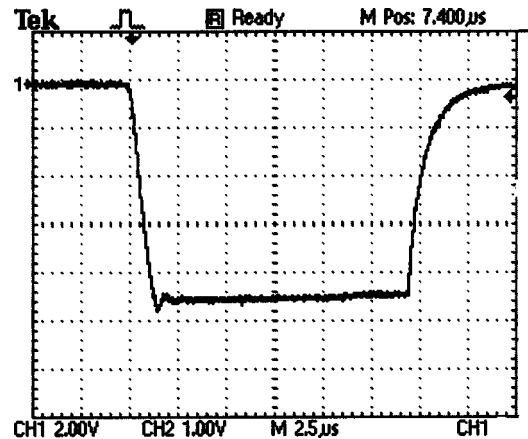

Figure 7: Typical HVPM 100-150 Pulse; 80kV, 90A Into water Resistor

### 2. 70 kV DC Step-Down Transformer / Rectifier

The step-down transformer is a standard utility outdoor transformer (~ 50 MW). It transforms power from 230 kVAC to approximately 70kVAC (in the 100 kV DC example used here). This is the equivalent of the transformer needed to go from 230 kVAC to 13.8 kVAC in the conventional approach. Up to this point, the DC distribution approach is very similar to the conventional AC approach. This 70 kVAC power is then rectified to provide 100+kV unregulated DC power.

### 3. DC Distribution / Switchgear

The unregulated, 100+kVDC power is distributed throughout the facility using single pole, outdoor, pole-top switchgear and fuses. This equipment replaces the 3-phase 13.8 kVAC switchgear used in the conventional approach, and has the advantage of being simple, inexpensive, and essentially maintenance free.

### 4. Switching Buck Regulator

The key component in the DC distribution and control approach uses DTI's PowerMod™ solid state high voltage switch in a 'switching buck regulator' configuration. The switch is composed of a patented series stack of high power insulated gate bipolar transistors (IGBTs). The IGBT switch is used to Pulse Width Modulate (PWM), or Pulse Frequency Modulate (PFM), this higher, unregulated voltage from the rectifier down to a diode stack and LC filter. The high speed variable PWM/PFM switching serves as the voltage regulator for the system, allowing control of the output voltage over a wide range (5-100kV) at constant power output. If the switching frequency is much higher than the AC frequency (i.e., 5-30 kHz vs. 60 Hz), the PWM can actively compensate for rectifier

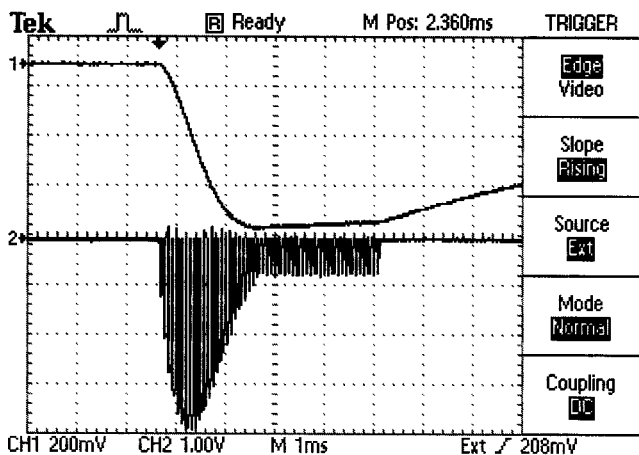

Figure 8: Buck Regulator Demonstration Pulse. Trace 1-Voltage; Trace 2-Switch Current

ripple, as well as provide very fast voltage regulation in pulsed operations.

The only magnetics required in this regulator is the series inductor. This inductor, shown in Figure 9, is an air core assembly which measures approximately one cubic foot. It is inexpensive to build, since it consists of a single layer winding, and no metal core.

Figure 8 shows a typical output voltage (top trace) and switch current (lower trace) from a buck regulator demonstration at DTI, using a commercial DTI 3 MW peak power modulator. The pulse illustrates a working

buck regulator with a pulse duration of a few milliseconds. The switch current is large for approximately a millisecond in order to charge the output capacitor filter. The flat top current and voltage are due to the resistive output load. The only limitation on this demonstration was the input power available in our test stand. As this demonstration shows, DTI's solid state switches are ideally suited for use as buck regulator switches.

### 5. Fast Series Switch.

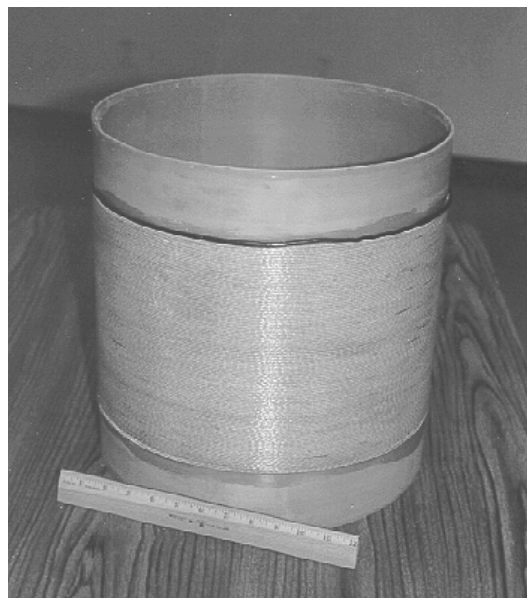

Figure 9: Inductor

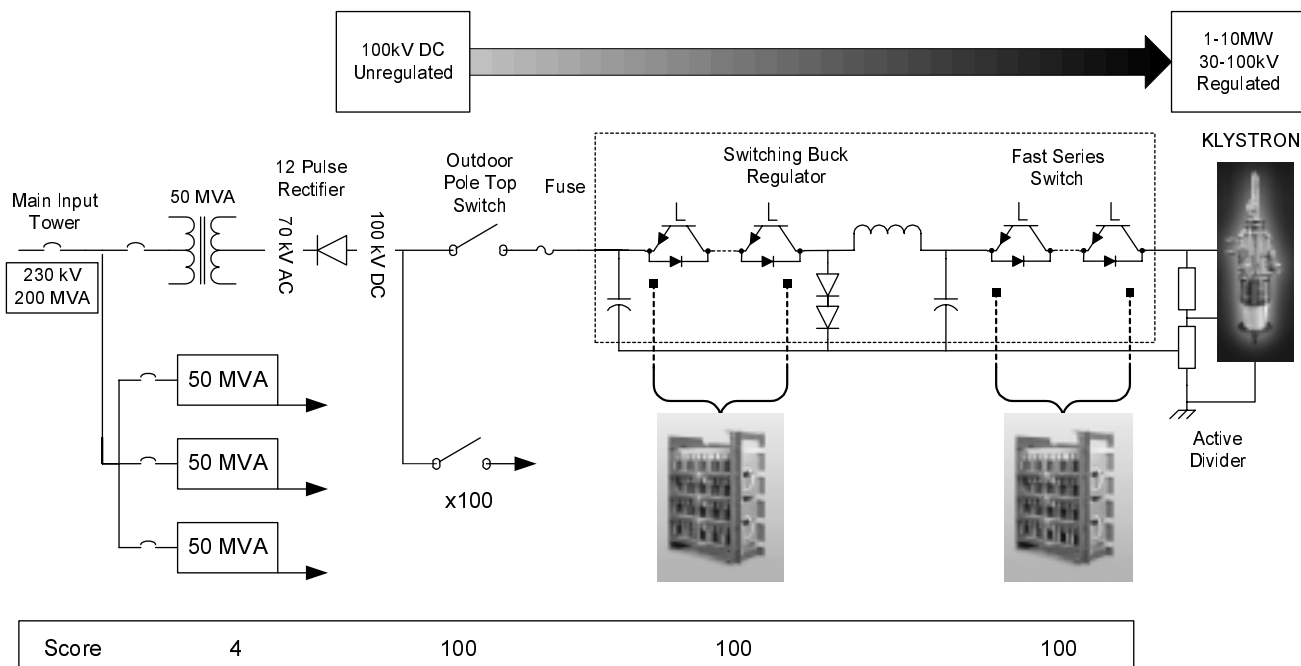

Figure 10: High Frequency DC Power Distribuion & Control

A second solid state high voltage IGBT switch serves both as a pulse modulator (where needed) and as a fast disconnect in the event of a klystron arc. This switch can detect an arc and open in less than 600 nanoseconds, thereby preventing damage to the klystron much more effectively than a crowbar. For pulsed systems, the speed of the switch allows pulse-to-pulse agility from 1 microsecond to DC, at pulse repetition rates up to and beyond 10 kHz.

The entire buck regulator and series switch combination is essentially composed of two of the solid state modulators shown in Figure 5. These units, approximately 60 ft<sup>3</sup> each, replace all of the equipment after the initial distribution transformer in the conventional approach.

### ***A Comparison of Conventional And DC Distribution and Control***

#### **Simplicity**

The DC power distribution and control approach requires far fewer components than the conventional approach. More importantly, it is the large, expensive components, such as the large transformers, series-pass tubes, and 13.8 kV switchgear, that are no longer needed. The power control scorecard shown in Table 2 emphasizes the difference.

#### **Efficiency**

DC Distribution and Control eliminates 60 Hz SCR regulators and series-pass tube regulators / switch tubes, improving the efficiency and lowering the cost of power delivery. Primary 60 Hz SCR controllers have a bandwidth intrinsically limited to below the 360 Hz switching speed of the SCRs. On the other hand, a 20 kHz switch has nearly two orders of magnitude higher regulation speed capability. With high speed regulation, the series mod- regulator tube is not necessary, and as much as a 10 kV to 20 kV voltage drop out of 100 kV (200 kW – 400 kW at 2 MW) is no longer wasted. This is an immediate increase of 10%-20% in overall efficiency.

For a 100 kV series switch, the comparable voltage drop is 200V (4 kW, or 0.2%). The efficiency from the overall buck regulator / series switch combination is estimated at over 98%. In a 2 MW CW system, each percent of inefficiency wastes approximately \$10,000 per year in electricity costs<sup>1</sup>, so eliminating the voltage regulation tube alone is worth \$100K-\$200K per year in cost savings. This cost savings alone may justify the selection of solid state switching power supplies for future high power systems.

Finally, increased efficiency significantly reduces the

<b>Power Control Scorecard 200 MW System</b>			
	Traditional	Solid-State	Savings
Transformers	204	4	200
Transitions/ Conversions	4	2	2
High Voltage Tubes	300	0	300
Power Supplies	400	100	300

Table 2

need for cooling systems to support the power distribution and control system, further minimizing infrastructure and facilities costs.

#### **Reliability**

The conventional AC power distribution architecture offers several “single points of failure”. When one of these points fails, the entire power supply chain for a klystron is brought down. The risk of system failure is much lower with DC distribution and control.

Solid-state, high voltage switches are the key to the reliability of DTI’s patented architecture. The IGBTs used in these switches are rated to have lifetimes in the millions of hours. Each solid state switch consists of a number of IGBTs in series, typically derated by 30% or more. IGBTs, if they fail, fail shorted. This allows continued operation of the switch, even when individual elements fail. Any failed modules need only be replaced during routine periodic maintenance.

#### **Flexibility**

The modularity of solid state electronics enables this basic design to be scaled relatively easily to different voltage levels and power requirements. DTI’s power supply design is flexible enough to be delivered in virtually any voltage (up to 200 kV) and current (up to 2000A) combination – without significant engineering or modifications to manufacturing processes.

Finally, the use of a second fast series switch brings an unprecedented level of flexibility to pulsed power systems. These switches can provide pulses between 1 microsecond and DC, in response to arbitrary pulse commands. They can also operate at 20 kHz and

<sup>1</sup> At \$0.05/kWh

beyond. DTI's high voltage switches are both opening and closing switches, eliminating the need for the special crowbar protection circuitry required in conventional power distribution systems.

### **Cost**

The entire power supply system shown in Figure 10 can be built with commercially available components, and fabricated through conventional electronics assembly techniques. No specialized machinery is required to assemble it, and no complex magnetics are used in construction. Even the largest assemblies can be moved easily with a manual pallet truck.

The largest cost components in this design are the semiconductors (IGBTs). Because of their widespread use in locomotive engines, subway cars, elevators, and a wide range of electrical motor drive and power supply systems, these devices are evolving at a rapid pace, especially in comparison with vacuum switch tubes. In the last decade, we have seen the switching speed and power handling capability of IGBTs increase by an order of magnitude (200 kVA to 4 MVA), at essentially constant prices. **This puts high power electronics, for the first time, on a favorable, long term cost reduction path. This is the equivalent of the computer industry's Moore's Law of continually higher performance per unit cost, but applied to power systems.**

Today, a 100 kV, 2MW buck regulator, with a series switch, can be built for approximately \$500k USD. This cost will decline due to increased semiconductor performance and decreased manufacturing costs. In contrast, estimates for the equivalent conventional approach are \$2- 3M USD, and show no trend towards cost reduction.

### **Summary**

In the 1890's, the initial contest between AC and DC power distribution was clearly won by George Westinghouse with AC distribution. This was due to the lower cost, higher reliability, and greater flexibility of his approach. As high power RF systems such as radars and accelerators were built, these advantages led to the nearly universal utilization of AC power distribution and control in these systems.

The emergence of high power, solid state electronics capabilities enables a new architecture for these systems - DC power distribution and control. The components to build and operate such a system have been successfully demonstrated by DTI. Dozens of DTI solid state switches are currently in operation around the world.

We believe that the advantages of this new technology will lead to the use of DC distribution and control for future high power RF systems. This will mean...

- Lower Capital Acquisition Cost
- Higher Levels of Tube Protection
- Higher Efficiency
- High Reliability
- Lower Lifecycle Cost

...for the radar, accelerator, and fusion engineering communities worldwide.

© 1998, 1999 Diversified Technologies, Incorporated. All rights reserved. Not to be reproduced by any means without the permission of Diversified Technologies. Specifications subject to change without notice. *Solid State High Voltage DC Power Distribution & Control* is one in a series of DTI Technical Briefs. Additional copies may be obtained by contacting DTI at 35 Wiggins Avenue, Bedford, MA USA 01730. Tel: 781-275-9444 FAX: 718-275-6081. Visit our website at [www.divtecs.com](http://www.divtecs.com) for more information on the line of high power, high voltage, solid-state systems available from Diversified Technologies. ❖

