



PowerMod Technology Breakthrough Brings High Availability to High Power Electronics

PowerMod™ High Voltage Pulse Modulators



PowerMod 100-150 solid-state modulator, 100 kV, 100 A. Size 50" w x 36" d x 64" h. Oil and water cooled.

DTI's PowerMod modulators deliver the breakthrough advantages of solid-state high power switching to demanding pulsed power applications world-wide.

- Fast rise and fall times and outstanding pulse stability
- Modular design for high reliability
- Streamlined system design using an ultra-fast opening and closing switch
- High power at 3 kV-200 kV at up to 5,000 A
- Full internal self-protection against overvoltage and overcurrent conditions

Selected twice as one of R&D Magazine's 100 Most Significant New Products, PowerMod modulators offer the most cost-effective switching available. High efficiency and increased pulse flexibility are inherent in the PowerMod design. PowerMod modulators are essential components in radar, high energy physics, food processing, and other leading-edge applications.

PowerMod modulators offer better performance than modulators built upon vacuum tubes because solid state components offer higher reliability with long component life, and generate significantly lower operating costs due to high power conversion efficiency. Lower power consumption means lower utility costs and smaller environmental cooling requirements.

PowerMod™ Pulse Modulators	
Rise/Fall Time	50 ns - 5 μ s
Voltage Input	3 kV - 200 kV (custom solutions to 1 MV)
Peak Current	Up to 5000 A (higher currents available through parallel operation)
Pulse Width	< 1 μ s - continuous

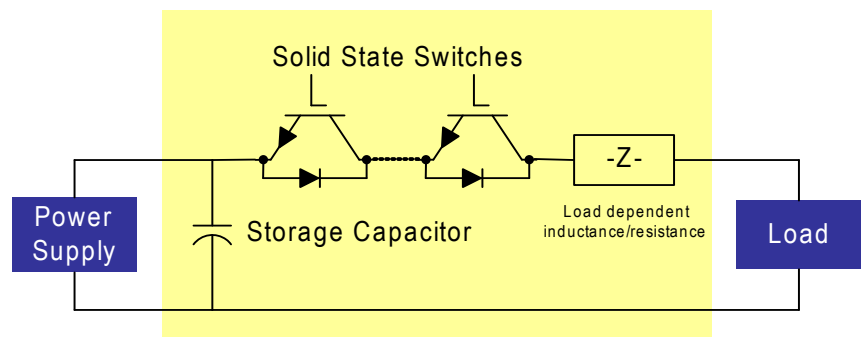

DTI's modulators are built upon this model of solid-state switches in series. A capacitor stores the energy from the power supply and provides high peak power and constant voltage during a pulse.



All DTI systems are built from patented, solid-state IGBT-based switching assemblies connected in series to achieve the desired voltage. Because IGBT switches always fail short, PowerMod modulators continue to operate, even if several switching assemblies fail. In addition, components are derated in the design, allowing additional operating margin.

DTI's pulse modulators behave as both closing and opening switches. In event of an arc, the switch opens instantaneously, protecting both the load and modulator from damage. The ability to open quickly removes the need for a crowbar in the circuit and leads to some important benefits. Without a crowbar, no series resistor is required and the system is more efficient. The energy-storage capacitor does not discharge during an arc, so pulsing can resume immediately after the arc clears. Finally, environmental hazards associated with mercury-containing ignitrons are eliminated.

PowerMod modulators are available in a wide range of voltage, current, and performance configurations.



PowerMod 20-150 3 MW, 30 kHz solid-state modulator. Size 19" w x 30" d x 24" h rack-mount. Forced air cooled.

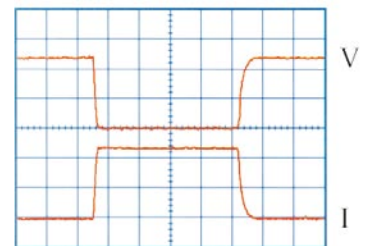

Very fast pulse rise and fall times ($<1\mu\text{s}$), and low ripple, produce a nearly ideal, flat-top pulse like this 20kV, 100A, $1\mu\text{s/cm}$. Upper trace voltage, lower trace current.

