

## Improving VED Transmitter Reliability

Michael A. Kempkes, Ian S. Roth, David A. Fink, Timothy J. Hawkey, Marcel P. Gaudreau  
*Diversified Technologies, Inc.*  
35 Wiggins Avenue, Bedford, MA USA 01730

Over the last decade, the introduction of solid-state pulse modulators and switching power supplies has revolutionized the design of VED transmitters. Virtually all of today's solid-state / VED radar transmitters have been upgraded from conventional systems. In many cases, the transition from switch tubes or thyratrons to solid-state systems was driven by the promised reliability of the solid-state components, rather than the higher performance of the solid-state modulators. Today, a number of upgraded systems have been in service long enough to provide data sufficient for assessing their reliability.

DTI has built and fielded over 300 solid-state pulsed power systems, many of which power VEDs: magnetrons, klystrons, TWTs, gyrotrons, and IOTs. Though DTI has built and fielded mod-anode and grid-pulsed systems, typically it is cathode-pulsed systems, where a solid-state switch is placed in series between a DC power supply and the VED cathode, that have been upgraded (Figure 1). The upgrade places multiple solid-state devices in series. If a single solid-state device in the series switch fails, it invariably fails shorted (similar to a diode string). With reasonable design margins, it is possible for 10 – 20% of the transistors to fail while the switch maintains fully-specified performance.

To perform a reliability assessment, DTI contacted several of the company's radar and klystron transmitter customers. Many of their systems are not operated continually, so it can take many years to achieve a significant number of operating hours. Nevertheless, three conclusions were obvious. First, all failures of the power supplies or modulators are directly attributable to an error in installation or operation. These errors were failure to connect the overcurrent sensor into the modulator control, inadvertent overvoltage of the modulator, and failure of the cooling system. Second, none of these systems had a VED fail during operation. Third, even for systems used intermittently (such as Cobra Judy X-band shown in Figure 2), the operational availability was essentially 100% after the upgrade was completed. For example, the Cobra Judy X-band transmitter, which had originally been the major source of problems in the entire system, has ceased to be a cause of system down-time since its upgrade.

DTI-fielded transmitter systems with significant operational data are shown in Table 1. Note that the greatest number of hours to date is with the MIT Bates Accelerator. There are also industrial systems using this same solid-state technology with comparable reliability statistics.

Combining the data from these systems, the *minimum* transmitter MTBF associated with this experience is 350,000 hours at a 60% confidence level. This compares very favorably with the MIL-HDBK-217F analysis performed on the AN/SPG-60 transmitter (Figure 3). The solid-state switch at the core of the modulator was estimated to have an MTBF of 423,000 hours. For the entire transmitter, the predicted MTBF was approximately 50,000 hours, limited by the cooling fans.

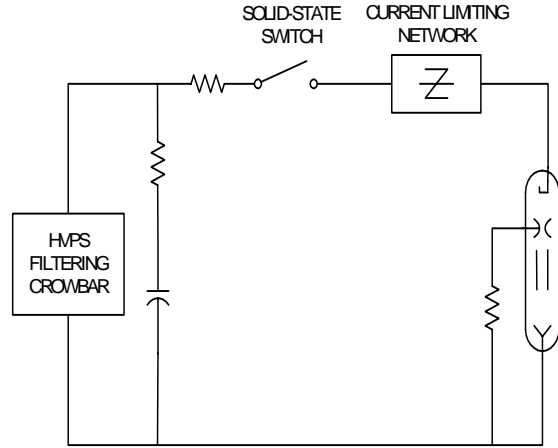

Figure 1. Schematic showing cathode pulsed VED transmitter with solid-state switch in series between the power supply and VED cathode.

Figure 2. Cobra Judy X-band installation on board USNS Observation Island.

Table 1. Cumulative Error-Free Operating Hours for Major Transmitters With DTI Upgrades.

| Transmitter                        | # of Fielded Units | System Operating Hours (as of 5/2005) |
|------------------------------------|--------------------|---------------------------------------|
| MIT Bates Linear Accelerator       | 10                 | 32,000                                |
| Multi-Target Instrumentation Radar | 1                  | 5,100                                 |
| AN/SPG-60 Radar                    | 12                 | 8,200<br>(Accelerated Life Test)      |
| Sondrestrom Radar                  | 1                  | 3,120                                 |
| Cobra Judy X-Band                  | 1                  | < 200                                 |

The fundamental limitation on the reliability of the transmitter comes from the solid-state devices which fail from heat. When the semiconductor junctions remain cool ( $T_{\text{junction}} < 100\text{ C}$ ), the devices have lifetimes in the millions of hours. However, every 10 C increase in  $T_{\text{junction}}$ , reduces their reliability by a factor of two. Therefore, careful attention to both the thermal design of the solid-state systems and maintenance of the modulator cooling systems are critical to achieving high reliability.

Solid-state transmitters increase the lifetime of VEDs. Most likely, this increased lifetime results from faster arc handling by the solid-state switch. Even in mod-anode and grid-pulsed systems, DTI uses a series cathode switch, which opens in  $< 1\ \mu\text{s}$  in response to an arc. The switch opens at relatively low current levels, and prevents the very high fault currents experienced in a transmitter during a typical crowbar. Eliminating these high currents (and their resulting fault energy levels) seems to be a critical element in extending VED lifetime. The opening of the series switch does not discharge the capacitors, or fault the power supply. The transmitter is able to resume operation as soon as an arc clears, as fast as milliseconds, often before the next pulse. From an operational point of view, this translates to significantly increased up-time.

In summary, combining VED RF amplifiers and solid-state modulators and power supplies is a proven means to build highly reliable high power transmitters. It is possible that the reliability of a solid-state VED transmitter may be limited solely by cathode depletion.



Figure 3. AN/SPG-60 radar cabinet. DTI's upgrade kit is installed in the lower compartment.